

Main Components and Options

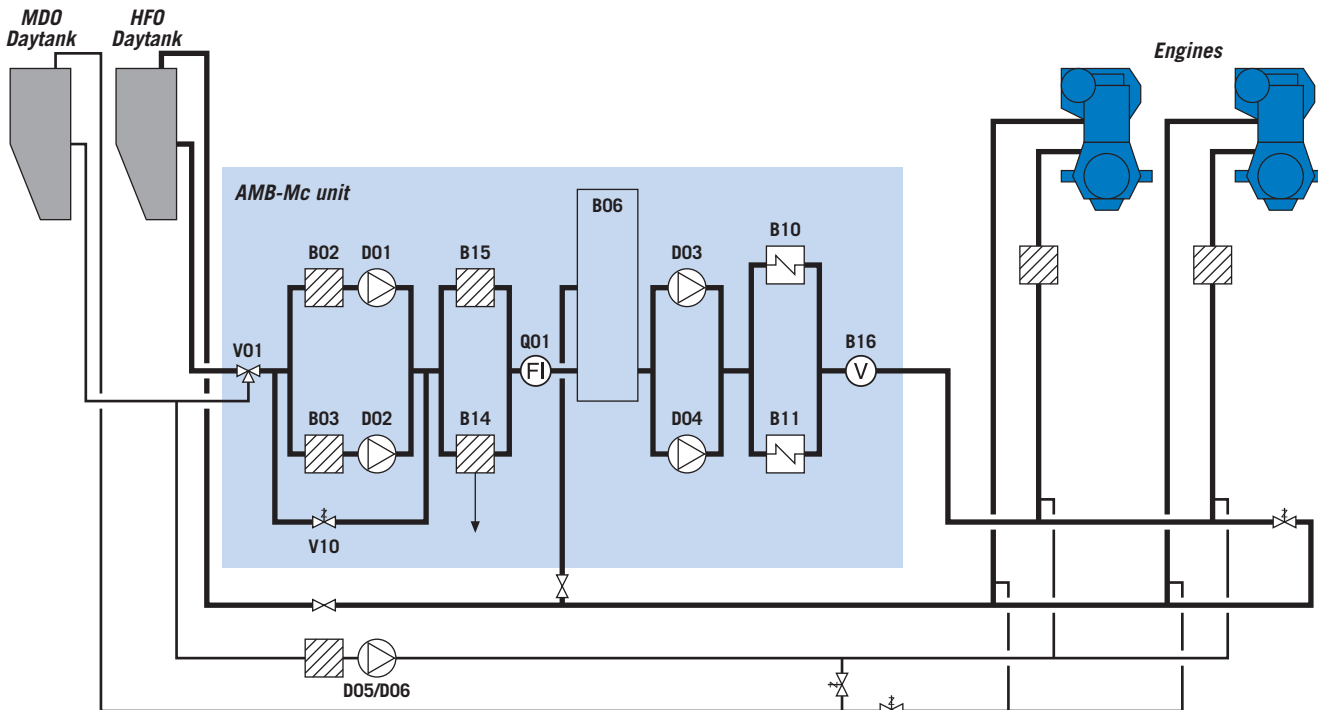

ITEM	COMPONENT	OPTIONS
V01	HFO/MDO 3-way changeover valve for selecting fuel and flushing the system	<ul style="list-style-type: none"> • None • Manual • Remote-controlled
B02-B03	Suction strainers for protecting the pumps	
D01-D02	Feeder pumps for pressurising the system with fresh fuel according to the consumption of the engines, equipped with an automatic stand-by function	
V10	Pressure control valve for maintaining constant system pressure at different loads	<ul style="list-style-type: none"> • Without bypass • With bypass
B14, B15	Automatic filter with bypass filter for removing impurities from fuel oil and indication of failures in purification system, equipped with automatic cleaning and pressure difference indication <i>* certain fuel types and flows call for a larger frame</i>	<ul style="list-style-type: none"> • 34 µm in cold side • 25 µm in cold side * • 10 µm in cold side * • 48 µm in hot side • 34 µm in hot side • 25 µm in hot side *
Q01	Flow meter for indicating fuel consumption	<ul style="list-style-type: none"> • None • With local totalizer • With local totalizer and output signal
B06	Mixing tank for mixing the return fuel from the engines with fresh fuel and for compensating for temperature and pressure changes	<ul style="list-style-type: none"> • Manual deaeration • Automatic deaeration
D03-D04	Booster pumps for further pressurising and circulating fuel to the engines, equipped with an automatic stand-by function	
B10-B11	Fuel heaters for heating the fuel oil to injection viscosity, controlled by a viscometer	<ul style="list-style-type: none"> • Steam heating (SS) • Thermal oil heating (TT) • Electric heating (EE)
B16	Viscosity control system for measuring the fuel viscosity and controlling the power of the heaters to maintain constant injection viscosity, secured by a temperature controller	<ul style="list-style-type: none"> • Controller and display located in the AMB unit • Controller loose delivery for remote operation
D05/D06	MDO pump for a separate MDO supply for auxiliary engines while running the main engines with HFO	<ul style="list-style-type: none"> • None • Pneumatic membrane type • Screw type with electric motor